

SUBJECT CODE NO:- K-03
FACULTY OF ENGINEERING AND TECHNOLOGY
T.E. (MECH/PROD) Examination Oct/Nov 2016
Design of Machine Elements - II
(Revised)

[Time: Three Hours]

[Max.Marks:80]

N.B Please check whether you have got the right question paper.

- N.B
- i) Attempt any three questions from each section.
 - ii) Assume suitable data, if necessary.
 - iii) Use of non-programmable calculator and design data book is allowed

Section A

Q.1 It is required to design a pair of spur gears with 20° full depth involute teeth consisting of a 20 teeth pinion meshing with a 50 teeth gear. The pinion shaft is connected to a 20KW, 1440RPM electric motor. The starting torque of the motor can be taken as 150% of the rated torque. The material for the pinion is plain carbon steel Fe 410 ($6wt\ 410N/mm^2$) while the gear is made of gray cast iron FG 200 ($6wt\ 200\ N/mm^2$) The factor of safety is 1.5. Design the gear based on Lewis equation and using velocity factor the account for the dynamic load. 14

Q.2 The pair of bevel gear is to be used to transmit 10kw. Number of teeth on pinion and gear are 20 and 60 respectively. The steel pinion meshes with C.I. gear. The safe bending stresses for steel and C.I are $85\ N/mm^2$ and $60N/mm^2$ respectively. Speed of pinion is 1200rpm and gear is 400rpm. The tooth profile is $14\ \frac{1}{2}^\circ$ composite. Design the pair, use $L=3b$, wear factor of 600 N/m. And dynamic factor of 80kN/m. Check out the design for wear and dynamic load $E_p=2.1 \times 10^5\ mpa$ & $E_g= 1 \times 10^5\ mpa$. $k_v = \frac{6}{6+v}$. 13

- Q.3
- a) Explain compound and reverted gear trains. 03
 - b) In an epicyclic gear train, an arm carries two gear A & B having 35 and 50 teeth respectively. If the arm rotates at 160rpm in the anti-clockwise direction about the centre of the gear. 'A' which is fixed, determine the speed of gear 'B'. If the gear 'A' instead of being fixed makes 300rpm in the clockwise direction, what will be the speed of gear B? 10

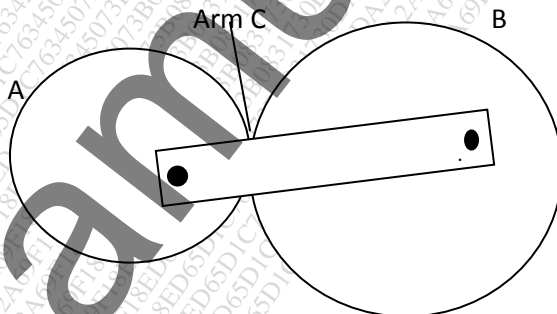

- Q.4 A multi plate disc clutch having steel and bronze plate is used to transmit 5 kw at 100rpm. The clutch operated in with oil with coefficient of friction 0.1 and the average allowable pressure of 350kN/m². If the inner radius and outer radius of contact area are 50mm and 80mm respectively. Find out. 13
- Total no. of discs of steel & bronze require
 - Axial force require to engage and disengage the clutch.
 - Average pressure
 - Actual maximum pressure
- Q.5 Write short notes on (any three) 13
- Thermal consideration in worm gear.
 - Centrifugal clutch
 - Formative no. of teeth on helical gear and bevel gear
 - Causes of gear failure

Section B

- Q.6 a) Explain hydrodynamic bearing. 04
 b) A 100mm diameter shaft operating at 2000rpm is supported in a 140mm long full journal bearing subjected to a radial load of 45KN. Operating temperature of oil is limited to 80°C and surrounding air temperature is 40°C. Assume $ZN/p=30 \times 10^{-6}$. Using McKee and Lasche equation, determine coefficient of friction, bearing pressure H_g and H_d and viscosity Z of the lubricant. 10
- Q.7 A single row deep groove ball bearing is subjected to a radial force of 6KN and thrust force of 2KN. The shaft rotates at 1200rpm. The expected life of bearing is 22,000 hrs. The minimum acceptable diameter of the shaft is 75mm. Select suitable ball bearing for this applications. 13
- Q.8 A flat leather belt is used to transmit 10kw from a pulley rotating at 750rpm to another pulley rotating at 250Rpm. The centre distance of the pulley is twice the diameter of larger pulley. The belt should operate at a constant speed of 20m/s approximately. The stress in the belt should not exceed 2.5 N/mm². The density of leather belt is 0.95gram/cc and coefficient friction between belt and pulley is 0.3. Belt thickness is 5mm. Calculate 13
- Diameter of pulley
 - Length and width of belt
 - Belt tension

- Q.9 Fig shows a configuration of a differential band brake. Assume $\mu=0.3$. 13
- Determine the tension in the band, if the braking torque of 200NM is applied to the drum, for the given direction of rotation.
 - Further design the band if the thickness of band is 3mm with $\sigma_{\text{safe}}=70\text{mpa}$.
 - Also calculate the heat generated during braking. If drum rotates at 150rpm.

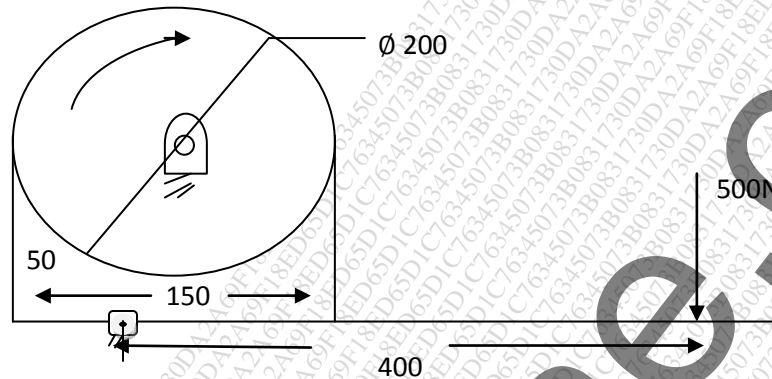

- Q.10 Write short notes (any three) 13
- Compare between V-belt drive and flat belt drive.
 - Brake lining material
 - Centrifugal clutch
 - Optimum design